



2/11 Mulgoa Way Mudgee NSW

5 🏠 3 🚗 2 🚗

Privately nestled in the sort after locale of Mudgee's East, a unique opportunity is now available to secure two modern, self-contained duplex residences on a 1,904sqm parcel of land.

Both units have established long term rental histories and are currently let at a combined rental return of \$980 per week. An exceptional and secure investment opportunity in a picturesque and tightly held east Mudgee location.

The property comprises of a three-bedroom, 2 bathroom unit and a two-bedroom 1 bathroom unit, which incorporate:

- Open plan living areas, overlooking the Cudgegong river and farmland to the north
- Large well-appointed kitchens, with plenty of storage and bench space
- Built-in wardrobes in all bedrooms
- Cassette split-system air conditioning throughout
- Private carports for each unit
- Basement garages offering additional storage, ideal for vehicles, trailers, mowers, etc.

Price : GUIDE \$900,000-\$950,000
Land Size : 1904 sqm
View : <https://www.thepropertyshop.com.au/sale/nsw/dubbo-orana/mudgee/residential/semi-detached/7743152>



Andrew Palmer
02 6372 2222



Patrick Power
02 6372 2222

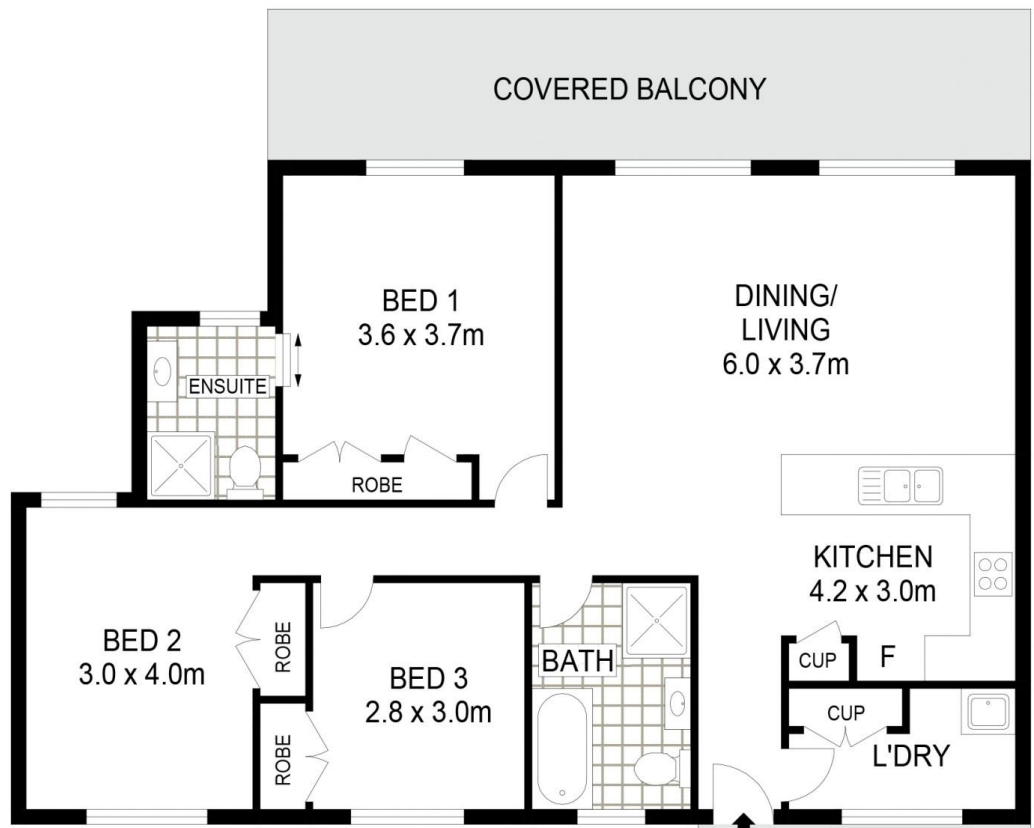

UPPER LEVEL

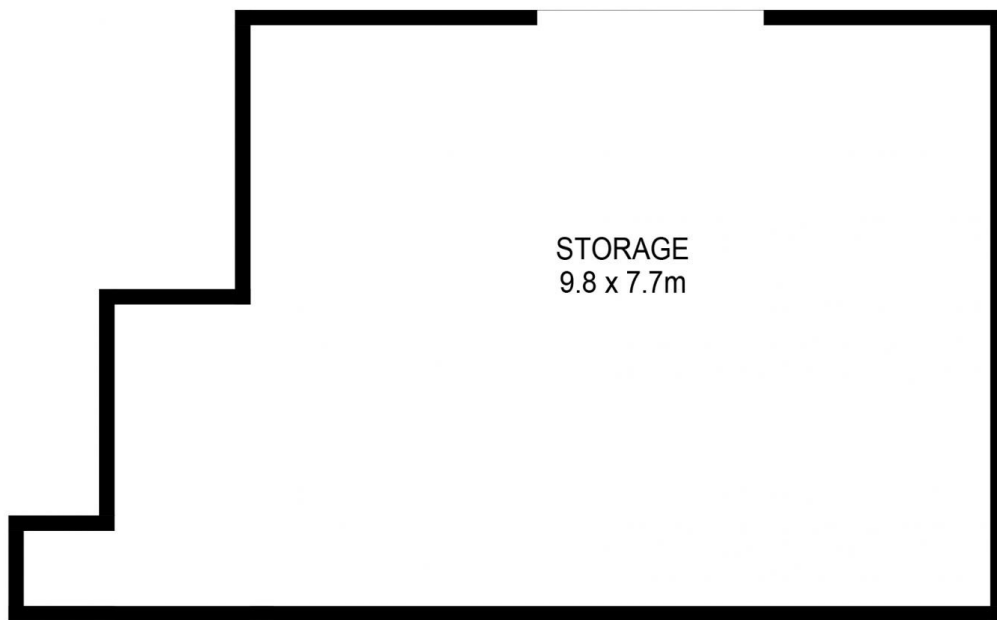
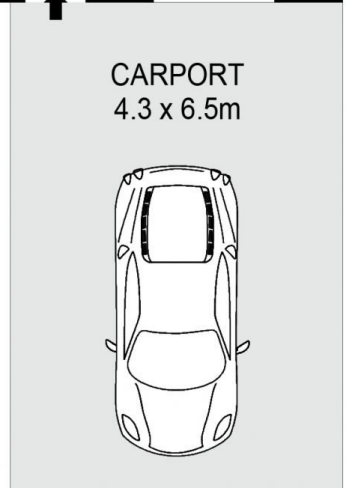

GROUND LEVEL

2/11 MULGOA ROAD

MUDGEE



Floor plans and rooms sizes are indicative only

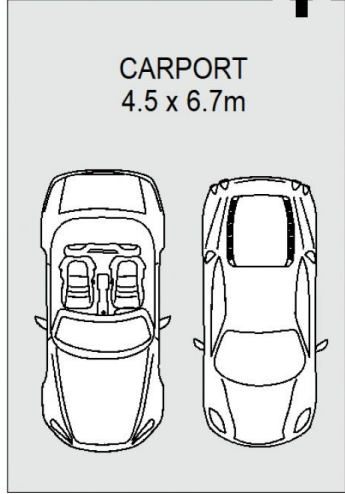
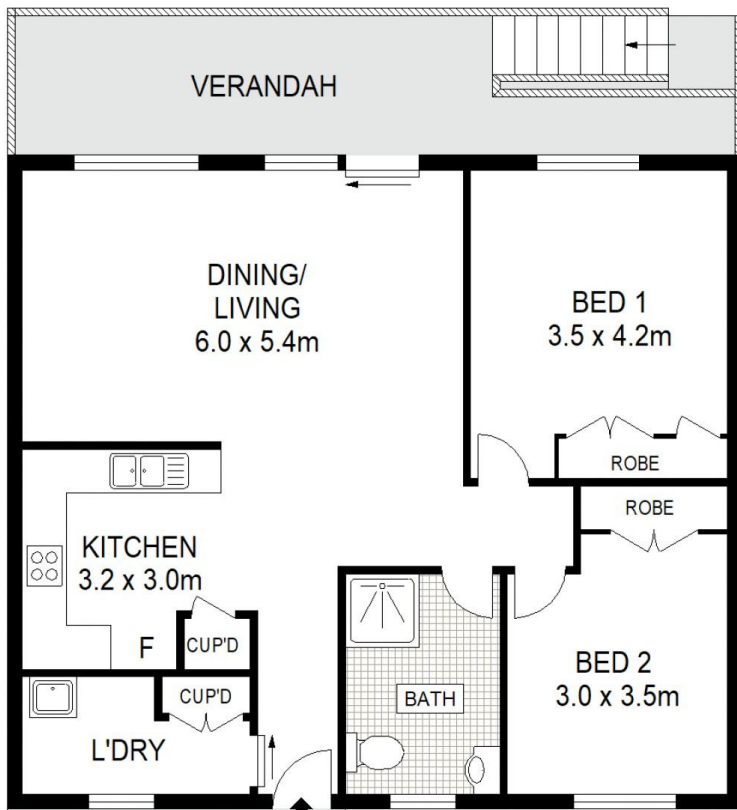

UPPER LEVEL

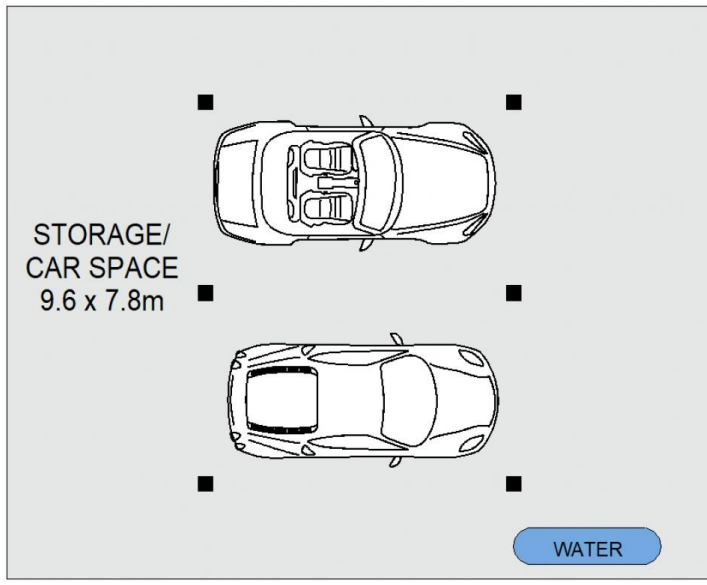

GROUND LEVEL

4/11 MULGOA WAY

MUDGEES



Floor plans and rooms sizes are indicative only